

How To Select And Use The Right Temperature Sensor

Presented at the 1996 Heat Processing Conference, Arlington Heights, Illinois, October 1996.

***By: Ron Desmarais
Production Manager
Pyromation, Inc.***

Introduction

Having been involved in the design, manufacture and application of temperature sensors for twenty years, I have done a number of training seminars on temperature sensors. After presenting long winded explanations as to how RTD's (Resistance Temperature Detectors) and thermocouples are constructed and used, people usually ask the question "OK, so how do I determine which sensor to use in my application?". This paper is intended to answer that question.

After a brief review of how RTD's and thermocouples are constructed and used to measure temperature, we will discuss what differentiates these sensors from one another. We will discuss the topics of temperature range, tolerance, accuracy, interchangeability and relative strengths and weaknesses for each type. After reviewing these topics you will have a better understanding as to when each type of sensor should be used and why.

Review of RTD and Thermocouple Basics

RTD's:

RTD's contain a sensing element which is an electrical resistor that changes resistance with temperature. This change in resistance is well understood and is repeatable. The sensing element in an RTD usually contains either a coil of wire, or a grid of conductive film which has a conductor pattern cut into it (see Figure 1). Extension wires are attached to the sensing element so it's electrical resistance can be measured from some distance away. The sensing element is then packaged so it can be placed into a position in the process where it will reach the same temperature that exists in the process (see Figure 2).

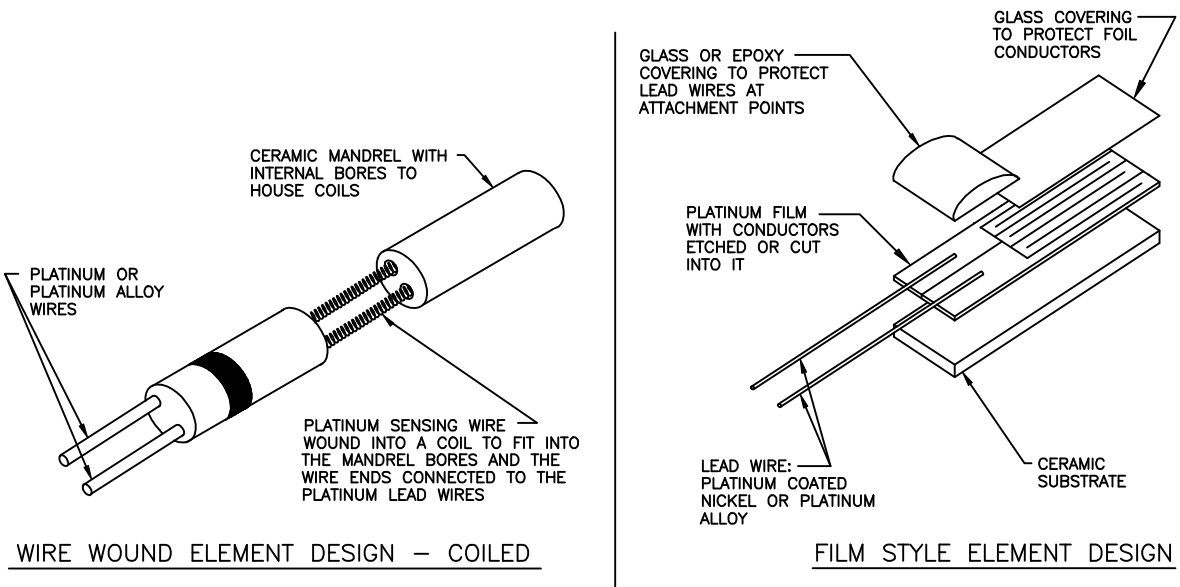

FIGURE 1: RTD ELEMENT CONSTRUCTIONS

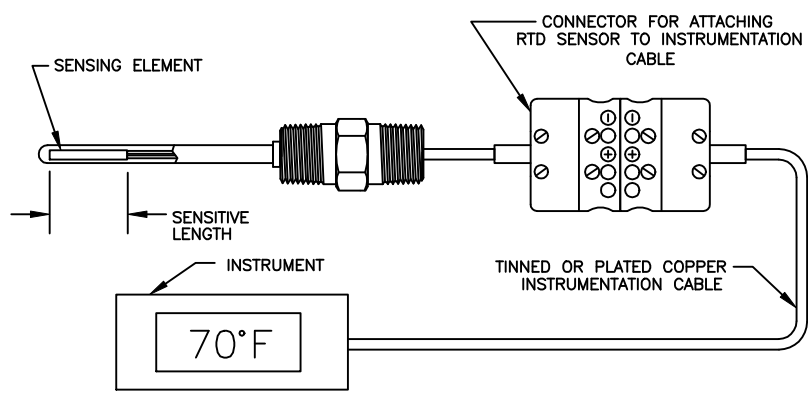

FIGURE 2: RTD SENSOR CONSTRUCTIONS

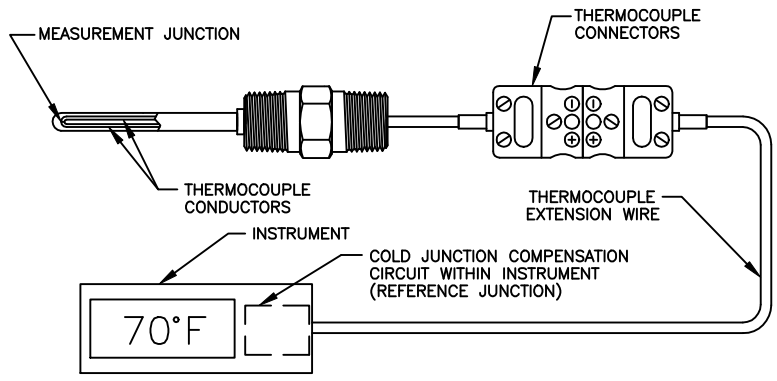

FIGURE 3: THERMOCOUPLE SENSOR CONSTRUCTIONS

Thermocouples:

Thermocouples, on the other hand, contain two electrical conductors made of different materials which are connected at one end. The end of the conductors which will be exposed to the process temperature is called the measurement junction. The point at which the thermocouple conductors end (usually where the conductors connect to the measurement device) is called the reference junction (see Figure 3).

When the measurement and reference junctions of a thermocouple are at different temperatures, a millivolt potential is formed within the conductors. Knowing the type of thermocouple used, the magnitude of the millivolt potential within the thermocouple, and the temperature of the reference junction allows the user to determine the temperature at the measurement junction.

The millivolt potential that is created in the thermocouple conductors differs depending on the materials used. Some materials make better thermocouples than others because the millivolt potentials created by these materials are more repeatable and well established. These thermocouples have been given specific type designations such as Type E, J, K, N, T, B, R and S. The differences between these thermocouple types will be explained below.

Temperature Limitations for RTD's and Thermocouples:

The materials used in RTD's and thermocouples have temperature limitations which can be an important consideration in their use.

RTD's

As stated earlier, an RTD consists of a sensing element, wires to connect the sensing element to the measurement instrument and some kind of support to position the sensing element in the process. Each of these materials sets limits on the temperature that the RTD can be exposed to.

Material	Usable Temperature Range
Platinum	-450°F To 1200°F
Nickel	-150°F To 600°F
Copper	-100°F To 300°F
Nickel/Iron	32°F To 400°F

The sensing element in an RTD usually contains a platinum wire or film, a ceramic housing and ceramic cement or glass to seal the sensing element and support the element wire. Typically, platinum sensing elements are able to be exposed to temperatures up to approximately 1200°F. Other materials such as Nickel, Copper and a Nickel/Iron alloy

can also be used, however, their useful temperature ranges are quite a bit lower than for platinum. Usage temperatures for all these materials are shown in Table 1.

The wires which connect the sensing element to the readout or control instrumentation are usually made of materials such as nickel, nickel alloys, tinned copper, silver plated copper or nickel plated copper. The wire insulation used also directly influences the temperature the RTD can be exposed to. Table 2 contains the commonly used wire and insulation materials and their maximum usage temperatures.

Table 2: Connecting Wire Temperature Limits	
Wire / Insulation Materials	Maximum Usage Temperature
Tinned Copper/PVC Insulated	221°F
Silver Plated Copper/FEP Teflon Insulated	400°F
Silver Plated Copper/TFE Teflon Insulated	500°F
Nickel Plated Copper/TFE Teflon Insulated	500°F
Nickel Plated Copper/Fiberglass Insulated	900°F
Solid Nickel Wire	1200°F

Placing the sensing element into the process also requires the use of materials. The most common arrangement used is to place the resistor and attached wires into a closed ended metal tube, pack the tube with a vibration dampening and/or heat transfer material such as ceramic powder, and seal the open end of the tube with an epoxy or ceramic cement. The metal tubes most commonly used in RTD's are made of stainless steel (used to approximately 900°F) or Inconel (used to approximately 1200°F). The vibration dampening/ heat transfer materials used vary widely in temperature range. These materials are selected by the manufacturer to provide the optimum performance based on the maximum temperature expected in use. Epoxy sealing compounds are typically never used above 400 to 500°F. Ceramic cements can be exposed to temperatures of 2000°F or more, but require sealants to keep moisture out of the cement and the vibration dampening/ heat transfer material beneath.

The material with the lowest temperature capability in a platinum RTD is usually the wire and insulation used to connect the sensing element to the instrumentation. Manufacturers typically offer two constructions, low temperature and high temperature. In low temperature constructions, Teflon insulated nickel or silver plated copper wire is used along with an epoxy seal. This construction is usually limited to 400 to 500°F.

High temperature constructions typically use fiberglass insulated, nickel plated copper wire and a ceramic cement which has a maximum temperature of 900°F to 1200°F. Some manufacturers also offer a line of RTD's which use a ceramic insulated nickel or nickel alloy wire for use up to 1200°F.

Thermocouples:

Thermocouple materials are available in Types E, J, K, N, T, R, S and B. These thermocouple types can be separated into two categories: Base Metal and Noble Metal thermocouples.

Type E, J, K, N and T thermocouples are known as Base Metal Thermocouples because they are made of common materials such as copper, nickel, aluminum, iron, chromium and silicon. Each thermocouple type has preferred usage conditions, for example the use of bare Type J thermocouples (Iron/Constantan) are typically limited to a maximum temperature of 1000°F and are not recommended for use in oxidizing or sulfurous atmospheres due to deterioration of the Iron conductor. Bare Type T thermocouples (Copper/Constantan) are not used above 700°F due to deterioration of the copper conductor. Temperature ranges for these thermocouple types are included in Table 3, and additional application information is included in Table 4.

Type R, S and B thermocouples are known as Noble Metal Thermocouples because they are made of Platinum and Rhodium. These thermocouples are used in applications that exceed the capabilities of Base Metal Thermocouples. Type R and S thermocouples are rated for use at temperatures between 1000°F and 2700°F, with Type B rated for use from 1000°F to 3100°F. When long term exposure at temperatures above 2500°F is expected, it is prudent to specify Type B thermocouples for improved thermocouple life. Type R & S thermocouples can experience significant grain growth if held near their upper use limit for long periods of time.

Since thermocouples do not have sensing elements, they do not have many of the temperature limiting materials that RTD's do. Thermocouples are normally constructed using bare conductors which are then insulated in a compacted ceramic powder or formed ceramic insulators. This construction allows thermocouples to be used at much higher temperatures than RTD's.

Tolerance, Accuracy and Interchangeability:

Tolerance and Accuracy are the most misunderstood terms in temperature measurement. The term tolerance refers to a specific requirement which is usually plus or minus some amount. Accuracy on the other hand refers to an infinite number of tolerances over a specified range.

For example, RTD's contain a sensing element which is manufactured to have a specific electrical resistance at a specific temperature. The most common example of this requirement is what's known as the DIN standard. To meet the requirements of the DIN standard, an RTD must have a resistance of 100 Ohms \pm 0.12 % (or 0.12 Ohms) at 32°F (0°C) to be considered a Grade B sensor (a Grade A sensor is 100 Ohms \pm 0.06%). The tolerance of \pm 0.12 Ohms applies only to the resistance at 32°F and cannot be applied to any other temperature. Many suppliers will provide an interchangeability table for

Table 3: Thermocouple Types, Temperature Ranges, Limits of Error

Table 3: Thermocouple Types, Temperature Ranges, Limits of Error					
Standard				Special	
Type	Materials	Temperature Range	Limits Of Error	Temperature Range	Limits Of Error
J	Iron/Constantan	32 To 559F (0 To 293C)	4F (2.2C)	32 To 527F (0 To 275C)	2F (1.1C)
		550 To 1400F (293 to 760C)	0.75%	527 To 1400F (275 To 760C)	0.40%
K	Chromel/Alumel	-328 To -166F (-200 To -110C)	2%		
		-166 To 32F (-110 To 0C)	4F (2.2C)		
		32 To 559F (0 To 293C)	4F (2.2C)	32 To 527F (0 To 275C)	2F (1.1C)
		559 To 2282F (293 To 1250C)	0.75%	527 To 2282F (275 To 1250C)	0.40%
T	Copper/Constantan	-328 To -89F (-200 To -67C)	1.50%		
		-89 To 32F (-67 To 0C)	1.8F (1C)		
		32 To 271F (0 To 133C)	1.8F (1C)	32 To 257F (0 To 125C)	0.9F (.05C)
		271 To 662F (133 To 350C)	0.75%	257 To 662F (125 To 350C)	0.40%
E	Chromel/Constantan	-328 To -89F (-200 To -67C)	1%		
		-274 To 32F (-170 To 0C)	3.1F (1.7C)		
		32 To 644F (0 To 340C)	3.1F (1.7C)	32 To 482F (0 To 250C)	1.8F (1C)
		644 To 1652F (340 To 900C)	0.50%	482 To 1652F (250 To 900C)	0.40%
N	Nicrosil/Nisil	32 To 559F (0 To 293C)	4F (2.2C)		
		559 To 2300F (293 To 1260C)	0.75%		
R	Platinum/Platinum-13% Rhodium	32 to 1112F (0 To 600C)	2.7F (1.5C)	32 to 1112F (0 To 600C)	1.1F (0.6C)
		1112F To 2642F (600 To 1450C)	0.25%	112F To 2642F (600 To 1450C)	0.10%
S	Platinum/Platinum-10% Rhodium	32 to 1112F (0 To 600C)	2.7F (1.5C)	32 to 1112F (0 To 600C)	1.1F (0.6C)
		1112F To 2642F (600 To 1450C)	0.25%	112F To 2642F (600 To 1450C)	0.10%
B	Platinum/Platinum-30% Rhodium	1472 To 3092F (800 To 1700C)	0.50%	1472 To 3092F (800 To 1700C)	

Table 4: Thermocouple Application Information	
Type	Application Information
E	Recommended for continuously oxidizing or inert atmospheres. Sub-zero limits of error not established. Highest thermoelectric output of the common thermocouple types.
J	Suitable for vacuum, reducing or inert atmospheres, oxidizing atmospheres with reduced life. Iron oxidizes rapidly above 1000°F (538°C) so only heavy gauge wire is recommended for high temperature. Bare elements should not be exposed to sulfurous atmospheres above 1000°F (538°C).
K	Recommended for continuous oxidizing or neutral atmospheres. Mostly used above 1000°F (538°C). Subject to failure if exposed to sulfur. Preferential oxidation of chromium in positive leg at certain low oxygen concentrations causes “green rot” and large negative calibration drifts most serious in the 1500 - 1900°F (816 - 1038°C) range. Ventilation or inert sealing of the protection tube can prevent this.
N	Can be used in applications where Type K elements have shorter life and stability problems due to oxidation and the development of “green rot”.
T	Usable in oxidizing, reducing, or inert atmospheres as well as vacuum. Not subject to corrosion in moist atmospheres. Limits of error published for sub-zero temperature ranges.
R & S	Recommended for high temperature. Must be protected in a non-metallic protection tube and ceramic insulators. Continued high temperature usage causes grain growth which can lead to mechanical failure. Negative calibration drift caused by rhodium diffusion to the pure leg of platinum as well as from rhodium volatilization. Type R is used in industry, Type S in the laboratory.
B	Same as R & S but has a lower output. Also, has a higher maximum temperature and less susceptible to grain growth.

RTD's which provide the user with a table of tolerances at specific temperatures (see Table 5):

Temperature	Tolerance At Temperature	
	Temperature	Resistance
-200°C	± 1.3°C	± 0.56 Ohms
-100°C	± 0.8°C	± 0.32 Ohms
0°C	± 0.3°C	± 0.12 Ohms
100°C	± 0.8°C	± 0.30 Ohms
200°C	± 1.3°C	± 0.48 Ohms
300°C	± 1.8°C	± 0.64 Ohms
400°C	± 2.3°C	± 0.79 Ohms
500°C	± 2.8°C	± 0.93 Ohms
600°C	± 3.3°C	± 1.06 Ohms

Thermocouples on the other hand are specified differently than RTD's because they are manufactured differently. Unlike the sensing element found in RTD's, the millivolt potential generated in a thermocouple is a function of the material composition and the metallurgical structure of the conductors. Therefore, thermocouples are not assigned a value at a specific temperature, but given limits of error which cover an entire temperature range.

These limits assigned to thermocouples are known as standard or special limits of error. Table 3 contains the standard and special limits of error specifications for each standard thermocouple type. It must be noted that the limits of error values listed in Table 3 are for new thermocouples prior to use. Once thermocouples are exposed to process conditions, changes in the thermocouple conductors may result in increased errors. Users are encouraged to perform tests periodically to determine the condition of thermocouples used in high reliability or close accuracy applications.

Strengths & Weaknesses

Each type of temperature sensor has particular strengths and weaknesses.

RTD Strengths:

RTD's are commonly used in applications where repeatability and accuracy are important considerations. Properly constructed Platinum RTD's have very repeatable resistance vs. temperature characteristics over time. If a process will be run at a specific temperature, the specific resistance of the RTD at that temperature can be determined in the laboratory and it will not vary significantly over time. RTD's also allow for easier interchangeability since their original variation is much lower than that of thermocouples. For example, a Type K thermocouple used at 400°F has a standard limit of error of ± 4°F. A 100 Ohm DIN, Grade B platinum RTD has an interchangeability of ± 2.2°F at this same temperature. RTD's also can be used with standard instrumentation cable for connection to display or

control equipment where thermocouples must have matching thermocouple wire to obtain an accurate measurement.

RTD Weaknesses:

In the same configuration, you can expect to pay from 4 to 10 times more for an RTD than for a base metal thermocouple. RTD's are more expensive than thermocouples because there is more construction required to make the RTD including manufacture of the sensing element, the hooking up of extension wires and assembly of the sensor. RTD's do not do as well as thermocouples in high vibration and mechanical shock environments due to the construction of the sensing element. RTD's are also limited in temperature to approximately 1200°F where thermocouples can be used as high as 3100°F

Thermocouple Strengths:

Thermocouples can be used to temperatures as high as 3100°F, generally cost less than RTD's and they can be made smaller in size (down to approximately .020" dia) to allow for faster response to temperature. Thermocouples are also more durable than RTD's and can therefore be used in high vibration and shock applications.

Thermocouple Weaknesses:

Thermocouples are less stable than RTD's when exposed to moderate or high temperature conditions. In critical applications, thermocouples should be removed and tested under controlled conditions in order to verify performance. Thermocouple extension wire must be used in hooking up thermocouple sensors to thermocouple instrument or control equipment. Use of instrumentation wire (plated copper) will result in errors when ambient temperatures change.

Summary:

Both thermocouples and RTD's are useful instruments for determining process temperature. RTD's provide higher accuracy than thermocouples in their temperature range because platinum is a more stable material than are most thermocouple materials. RTD's also use standard instrumentation wire to connect to the measurement or control equipment.

Thermocouples are generally less expensive than RTD's, they are more durable in high vibration or mechanical shock applications and are usable to higher temperatures. Thermocouples can be made smaller in size than most RTD's so they can be formed to fit a particular application.